

Model 7829

Bench Scale



NTEP CC 95-121



NCI Model 7829 shown with standard flat shroud and optional remote post display.

- **Capacity**– 250 lb x 0.05 lb (100 kg x 0.02 kg)
- **Construction**– Stainless steel weight platter. Painted mild steel base enclosure.
- **Power**– AC power
- **Operator Keys**– Zero and Test

VALUE IN
WEIGHING

Model 7829 Bench Scale

Features

The NCI Model 7829 Bench Scale provides the most accurate and reliable weight measurement for static or in-line shipping. The weighing solution for any application requiring a durable bench scale.

Display Controls– ZERO: Includes Auto Zero Tracking or Manual push button to re-establish zero reference. TEST: Runs a diagnostic test to ensure scales is fully functional, and allows a real-time view of internal settings.

Construction– Stainless steel weight platter. Painted mild steel base enclosure.

Field Calibration– Alternate span points can simplify field calibration by using less than full capacity weights. Can be set-up as either decimal pound or kilogram.

RS-232 Cable– Included with each scale, DB 9-pin, null modem, female connector allows you to connect to a PC

Emulation Protocols– Standard NCI default with field configurable settings of 8213, 3835, SMA, and Auto Weight Send. This allows you to select compatible scale communication settings or scale drivers during field installation when interfacing with shipping software programs or host devices.

Power Supply– Recessed power supply with standard wall plug

DuraBridge® Technology– Reduces overall scale deflection to less than 1/2" when a full load is applied

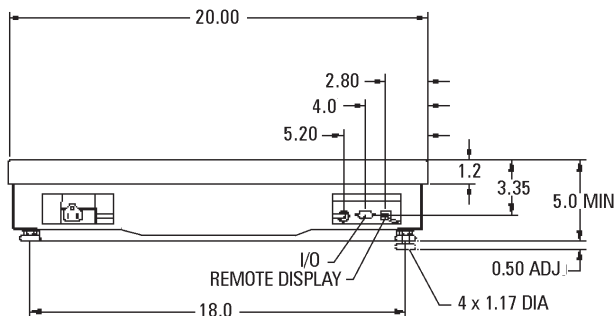

Specifications

Capacity– 250 lb x 0.05 lb (100 kg x 0.02 kg*)

Note: Default configuration as weight classifier.

** Metric weighing can be configured in the field during calibration.*

Dimensions– 20" L x 20" W x 5.3" H
51 cm (L) x 51 cm (W) x 13 cm (H)

Power– 120 VAC (+10% -15%), 60 Hz, standard 3-wire ground

Operating Environment–
Temperature: 42° F to 104° F (5° C to 40° C)
Relative Humidity: 10 to 95% (non-condensing)

Input/Output– RS-232, bi-directional, configurable 1200 – 19.2K baud. Transmits weight and scale status whenever ASCII "W" <CR> is sent by a remote device.

Shipping Weight–
54 lb (24 kg) standard configuration
73 lb (32 kg) with ball-top

Agency Approvals–
United States: NTEP #95-121
Canada: MOI #AM-5099
For use as a Class III device from +5° C to 40° C

Options

Ball-Top Weight Platter– Simplifies transport of all parcels. Ideal for conveyor lines. One piece lift-off design equipped with 25 balls.

Display– Post 12" post for remote display

Remote Display– 1/2" H, 6 digit LCD display housed in a molded enclosure with a 7 ft cable

International Power Supply– 230 VAC, 50 Hz power supply. End of cable terminated with a universal conductor.

C&M SCALE
Website: www.cmscale.com
Email: support@cmscale.com

Toll Free: (800) 243-3721
In Chicago: (708) 771-0195
Fax: (708) 771-0195