

STANDARD FEATURES

- Mild steel base construction
- 304 stainless steel cover
- Indicator stand for mounting IQ plus 355, IQ plus 390-DC, IQ plus 590-DC
- Polyurethane rubber leveling feet with stainless steel stem
- 8 in diameter preformed rubber with ball bearing
- 3 1/2 in diameter performed rubber two fixed, two swivel with lock



Ideal for Aviation Weighing. A complete system can be sold with the Tracer Av. Reference Instrumentation/Process Control for specifications

APPROVALS



SPECIFICATIONS

LOAD CELL, NTEP - CERTIFIED:

Aluminum, environmentally sealed

OUTPUT IMPEDANCE:

350 ohms

MAXIMUM OVERLOAD:

200%

OVERLOAD PROTECTION:

Five-point, independently adjusted

CABLE LENGTH:

10 ft (3m)

COMPENSATED TEMPERATURE RANGE:

14°F to 104°F/-10°C to 40°C

APPROVALS:

NTEP Certified 06-010A1, 5000 div
Measurement Canada Approved AM-5625

WARRANTY:

Two-year limited warranty

PART#

CAPACITY

PLATFORM DIMENSIONS (L X W X H)

Wheel model

93414.....	250 lb (125 kg)	30 in x 30 in x 8.75 in
93415.....	500 lb (225 kg)	30 in x 30 in x 8.75 in

Caster Model

93416.....	250 lb (125 kg)	36 in x 36 in x 8.75 in
93417.....	500 lb (225 kg)	36 in x 36 in x 8.75 in

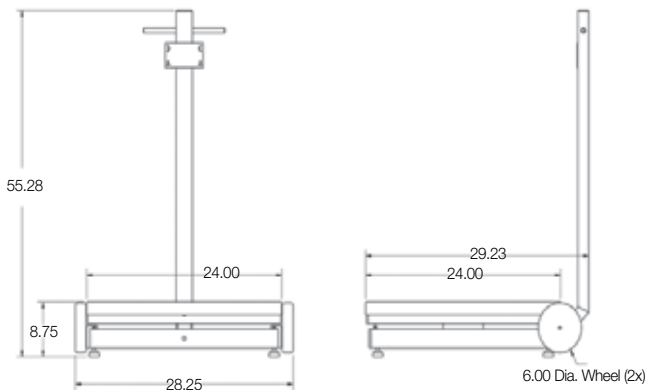

Wheel Model

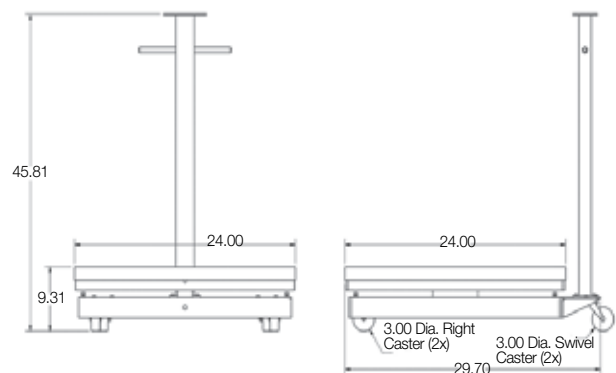

Caster Model

C&M SCALE
CALL FOR A QUOTE!
www.cmscale.com

Toll Free (800) 243-3721
Phone # (708) 771-0100
Fax # (708) 771-0195

PART #	CAPACITY	PLATFORM DIMENSIONS	EST. SHIP WEIGHT
Wheel Model			
97072.....	250lb.....	24 in x 24 in x 8.75 in	275 lb
97073.....	500lb.....	24 in x 24 in x 8.75 in	275 lb
Caster Model			
97074.....	250lb.....	24 in x 24 in x 9.31 in	290 lb
97075.....	500lb.....	24 in x 24 in x 9.31 in	290 lb

C&M SCALE
 CALL FOR A QUOTE!
www.cmscale.com

Toll Free (800) 243-3721
 Phone # (708) 771-0100
 Fax # (708) 771-0195