



IE Series

Crane SCALE



CAS
S • C • A • L • E

IE Series Crane Scale

Features

- 100 to 2000 lb capacities
- LCD or LED Display (1.1 inches/30mm)
- Battery Operated
- Low Battery and Overload Indicators
- High Intensity Hook and Shackle
- Heavy Duty Aluminum die cast case
- Includes:
 - AC Adapter
 - Rechargeable Battery
 - Wireless Remote Control

Applications

- Recycling
- Material Handling Applications
- Shipping/Receiving

Specifications

Model	IE Series				
Max Cap	100 x 0.05 lbs	200 x 0.1 lbs	500 x 0.2 lbs	1000 x 0.5 lbs	2000 x 1 lb
Ext Resolution	1/2000 - 1/3,000				
Max Tare	Full Tare				
Display Digit	5 Digits				
Display Type	LCD or LED				
Function Key	Power, Zero, Tare, Hold				
Operating Power	DC 9V/1500mA				
Remote Ctrl Range	10M				
Dimensions	8.9 (W) x 14.8 (H) x 5.1 (D) 225 (H) x 375 (H) x 130 (D)		8.7 (W) x 15.9 (H) x 5.1 (D) 225 (W) x 405 (H) x 130 (D)		
Product Weight	8.8 lbs / 4 kg		9.3 lbs / 4.2 kg		

Built Tough

Built to last with its sturdy aluminum die casting. The IE Series Crane Scale offers a compact portable design and will give you years of trouble free operation.

Hours of Use

A fully charged battery will offer up to 50 hours of use.

Easy to Read

Large 1.1 inch LCD or LED displays for easy reading from a long distance.

Dimensions

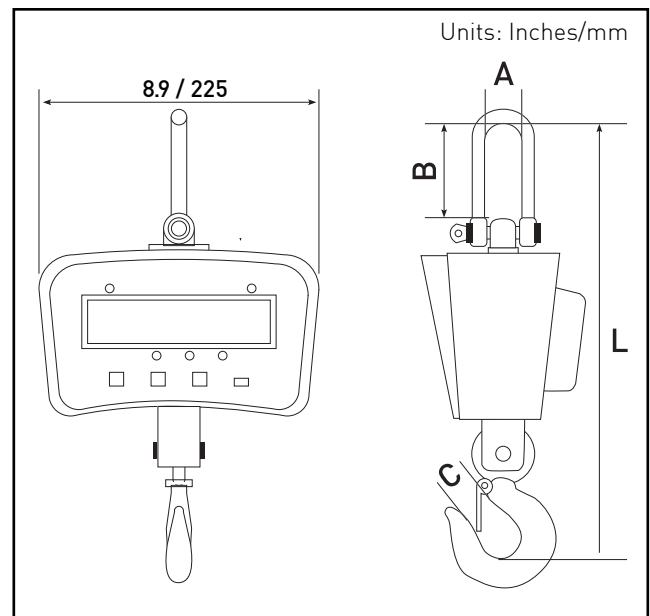

Model	IE Series				
Max Cap	100	200	500	1000	2000
L	13.2 / 335			14.2 / 360	
A	.8 / 20		.98 / 25		
B	2.6 / 65		2.95 / 75		
C	.8 / 20		.8 / 20		



C&M SCALE

Website: www.cmscale.com

Email: support@cmscale.com

Toll Free: (800) 243-3721
 In Chicago: (708) 771-0195
 Fax: (708) 771-0195