

Caston III

Crane Scale

- Available in 10000 lb × 2, 20000 lb × 5, 30000 lb × 10, 40000 lb × 10, 60000 lb × 20, 100000 lb × 20 Capacities
- Easy to Read 1.5" LED Display
- Wireless Remote Control Standard
- Environmentally Sealed to IP 65 Standards.
- Battery Operated



ISO 9001 certified

CAS
S · C · A · L · E

CASTON III Crane Scale

FEATURES

- Battery Operated w/Low Battery Indication
- Rechargeable Battery Pack
- Spare Battery Pack and Charger Included as Standard
- Easy to Read 1.5" LED Display
- Remote Control Included as Standard
- On,Off, Zero, Tare and Hold(Manual or Automatic) Functions
- Auto Span Adjustment
- Auto Zero Tracking

SPECIFICATIONS

Model	5THD	10THD	15THD	20THD	30THD	50THD
Weighing Capacity	10000×2lbs 5000×1kg	20000×5 lbs 10000×2kg	30000×10lbs 15000×5 kg	40000×10lbs 20000×50kg	60000×20 lbs 30000×10kg	100000×20lbs 50000×10kg
Maximum Tare	Full Tare					
Display Type	LED(1.5 inch)					
Operating Power	DC 6V					
Power Source	AC 120V, 50/60Hz					
Display Designators	Zero, Tare, Hold, Batt.					
Power Consumption	1.2W					
Operating Temperature	-10°C ~ +40°C (14°F ~ 104°F)					



▲ Display & Keyboard

◀ Battery pack Installation

CAS
S · C · A · L · E

C&M SCALE

Website: www.cmscale.com
Email: support@cmscale.com

DIMENSIONS

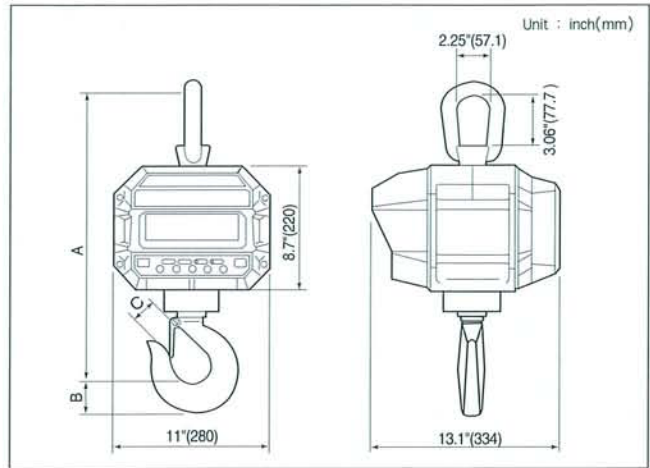

Model	A	B	C	Product Weight
5THD	20.1"(512)	1.75"(44.5)	1.69"(42.9)	68.3 lb / 31 kg

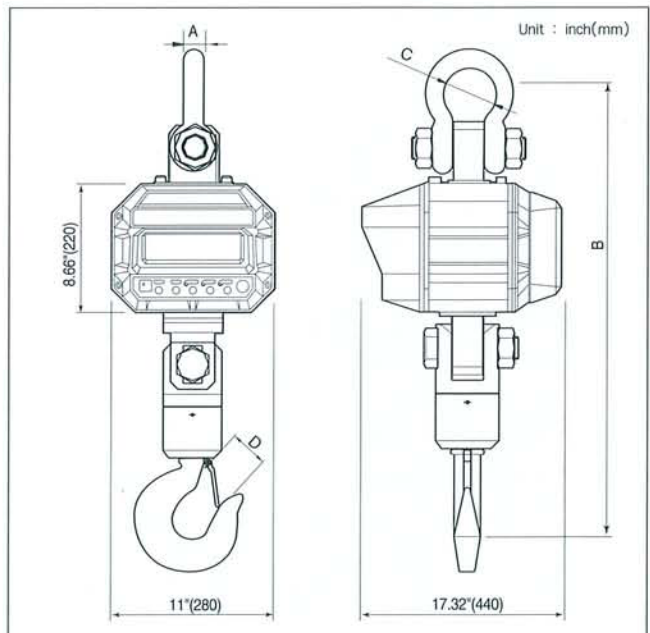

Model	A	B	C	D	Product Weight
10 THD	1.26"(32)	33.27"(845)	3.27"(83)	2.25"(57.2)	97 lb / 44 kg
15 THD	1.50"(38)	34.88"(886)	3.90"(99)	2.50"(63.5)	116.7 lb / 53 kg
20 THD	1.77"(45)	38.98"(990)	4.96"(126)	3.39"(86)	167.5 lb / 76 kg
30 THD	1.97"(50)	47.24"(1,200)	5.43"(138)	4.25"(108)	484.6 lb / 220 kg
50 THD	2.56"(65)	59.84"(1,520)	7.08"(180)	5.75"(146)	859.8 lb / 390 kg

Toll Free: (800) 243-3721
In Chicago: (708) 771-0195
Fax: (708) 771-0195