

**NEW**

# Summit® SB-1000

Bariatric/Wheelchair Scale

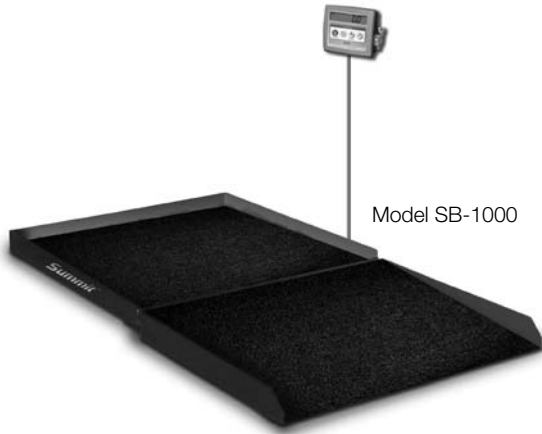

## STANDARD FEATURES

- 36 in W x 36 in L - 1,000lb mild steel painted scale with anti-slip rubber surface and three-sided safety rails
- Access ramp 36 in W x 28.5 in L with anti-slip rubber surface
- Large 1 in liquid crystal display (LCD)
- AC adaptor and internal rechargeable battery
- Pushbutton or manual entry of tare weight
- Unit of measure: lb only, kg only, lb/kg
- 10ft interface cable from scale to indicator
- RS-232 port
- BMI (body mass index) function
- Reweigh function
- Hold function

## APPROVALS



## SPECIFICATIONS

### POWER:

9VDC, provided by AC adaptor or internal rechargeable battery

### BATTERY TYPE:

Sealed lead acid

### APPROVALS:

CE

### BATTERY USE:

75 hours  
Automatic power-off can be configured from 0-20 minutes

### OPERATING TEMPERATURE:

50°F to 104°F  
(14°C to 40°C)

### WARRANTY:

Two-year limited warranty

DIMENSIONS	
<b>A</b> 36 in	<b>D</b> 36 in
<b>B</b> 36 in	<b>E</b> 4 in
<b>C</b> 28.5 in	<b>F</b> 1 in

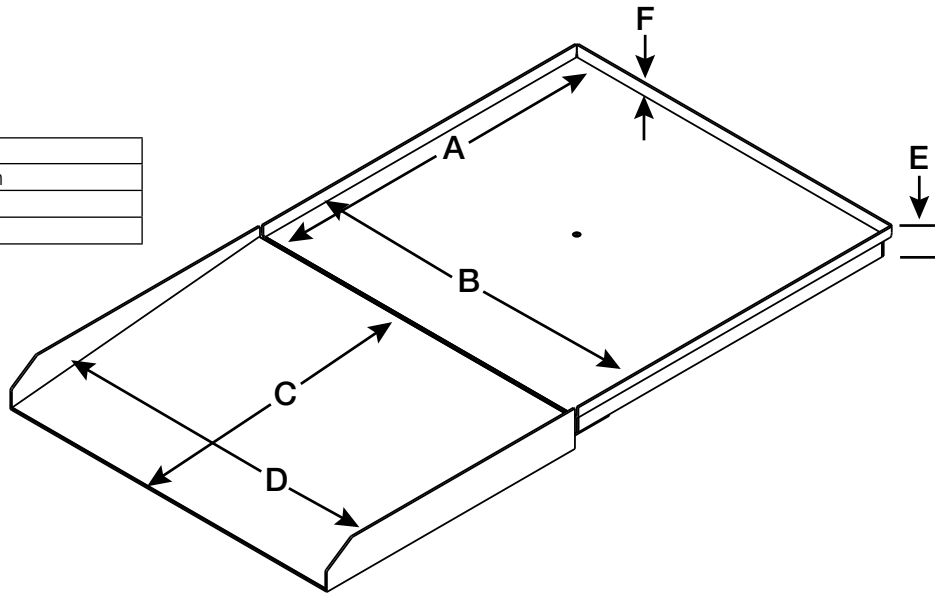

PART #	MODEL	CAPACITY	EST. SHIP WEIGHT
106658.....	SB-1000.....	1000lb (500kg) x 0.2lb (0.1kg).....	370 lb .....

**C&M SCALE**  
 CALL FOR A QUOTE!  
[www.cmscale.com](http://www.cmscale.com)

Toll Free (800) 243-3721  
 Phone # (708) 771-0100  
 Fax # (708) 771-0195