

# Bariatric/Handrail Scales



Model 240-10

## STANDARD FEATURES

- Capacity: 700lb x 0.2lb (310kg x 0.1 kg)
- Platform dimensions: 20 in x 25 in x 3 in
- Handrails for extra support and safety
- Integrated wheels for ease of portability
- Large 1 in LCD display
- Low battery indicator/automatic power-off
- BMI (body mass index) function
- Reweigh function
- Hold function
- Unit of measure: lb only, kg only, lb/kg
- RS-232 output
- Updatable firmware

## SPECIFICATIONS

### POWER:

9VDC, provided by AC adaptor or internal rechargeable battery

### BATTERY TYPE:

Sealed lead acid

### BATTERY USE:

75 hours  
Automatic power-off can be configured from 0-20 minutes

### OPERATING TEMPERATURE:

50°F to 104°F (14°C to 40°C)

### APPROVALS:

CE

### WARRANTY:

Two-year limited warranty

| DIMENSIONS |       |          |         |
|------------|-------|----------|---------|
| Eye Level  |       |          |         |
| <b>A</b>   | 20 in | <b>D</b> | 25 in   |
| <b>B</b>   | 25 in | <b>E</b> | 34 in   |
| <b>C</b>   | 3 in  | <b>F</b> | 44.5 in |



Bariatric/Handrail scale indicator

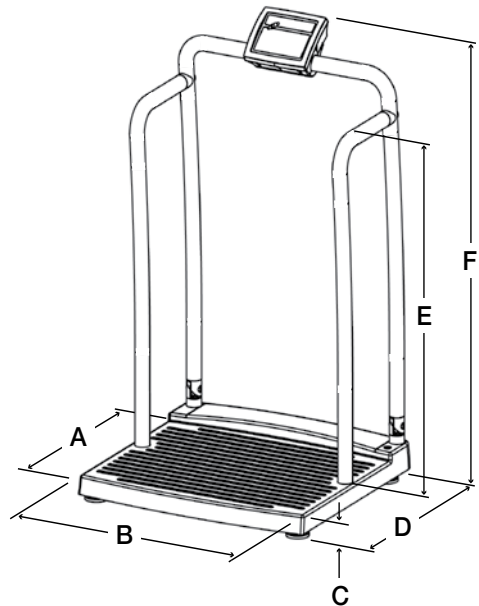

| PART #      | MODEL        | CAPACITY                                                      | EST. SHIP WEIGHT | PRICE |
|-------------|--------------|---------------------------------------------------------------|------------------|-------|
| 100193..... | 240-10 ..... | 700lb (310 kg) x 0.2lb (0.1 kg) includes 120V AC adaptor..... | 28 lb .....      |       |
| 100195..... | 240-10 ..... | 700lb (310 kg) x 0.2lb (0.1 kg) includes 230V AC adaptor..... | 28 lb .....      |       |

## OPTIONS

|             |                                                                                  |
|-------------|----------------------------------------------------------------------------------|
| 100719..... | RS-232 cable, 4ft cable DB9 female to RJ-45 (use with Healthweigh products)..... |
| 72704.....  | USB to serial convertor .....                                                    |

**C&M SCALE**  
CALL FOR A QUOTE!  
www.cmscale.com

Toll Free (800) 243-3721  
Phone # (708) 771-0100  
Fax # (708) 771-0195