

Heavy-Duty Bench Scales Series 1100

• Large 19" Dial • 15" Diameter Reading Line

Designed for industrial use where high accuracy, sturdy construction and minimum maintenance are necessary.

Detecto's compact and rugged Series 1100 Heavy-Duty Bench Scales offer high accuracy and sturdy construction with minimum scale maintenance.

The 1100 Series offers high capacities with accuracies to within 1 oz. **Thermal Elastic Temperature-Compensating Springs and Oil Dashpot** are standard and add long term accuracy.

The underlying principle of the Detecto 1100 Series is precision engineering with every component part specially designed to ensure sustained, long-term accuracy under prolonged usage.

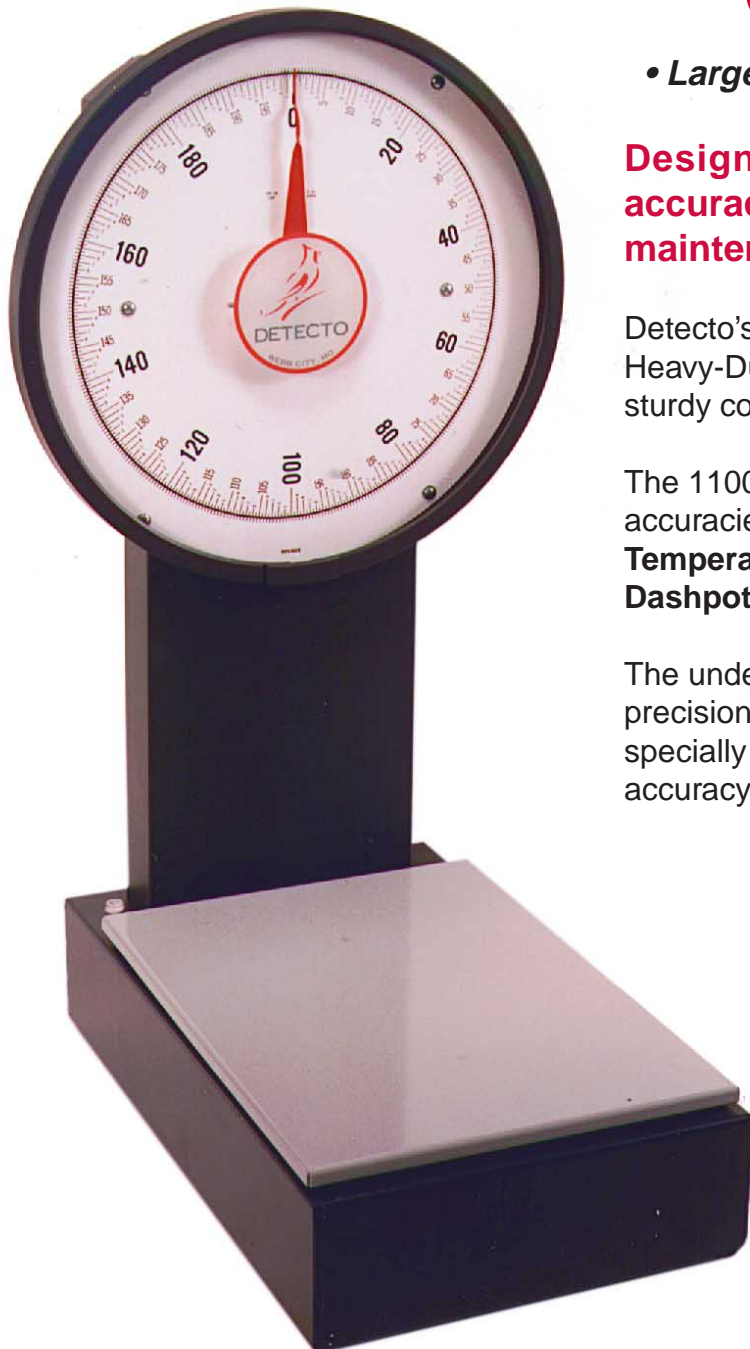

Available with adjustable rubber wheeled stand and special "L" stainless steel pan.

Detecto Series 1100 Heavy-Duty Bench Scale

... for Wherever You Need an Accurate, Sturdy, Reliable Receiving Scale!



Components of Detecto's Series 1100 scale are designed for accuracy under prolonged use with low maintenance. Special tip locks and bearings prevent platform tipping which avoids pivot and bearing abuse and assures accurate long life weighing. Side checks bring the platform to rest quickly, providing accurate readings from the large 15" dial. Zero adjustment is located on the top outside of the dial housing making it readily accessible.

Platform: 13 3/4" x 18 1/2"

Model	Capacity
1100DB	50 lb x 1 oz
1102DE	100 lb x 2 oz
1102EDX	100 lb x .1 lb
1105DG	200 lb x 4 oz

Model	Capacity
1106DK	300 lb x 8 oz
1100DBK	25 kg x 25 g
1102EDK	50 kg x 50 g
1106DKK	150 kg x 250 g

Options:

- Wheeled stand adjustable in 1" increments
- Stainless steel pans for special requirements.
- Kilos and libra dial charts
- Other capacities available upon request



Detecto 1100 Series Bench Scale meets all requirements of Handbook 44, issued by the National Institute of Standards and Technology, and has been issued the Certificate of Conformance Number 89-032A2

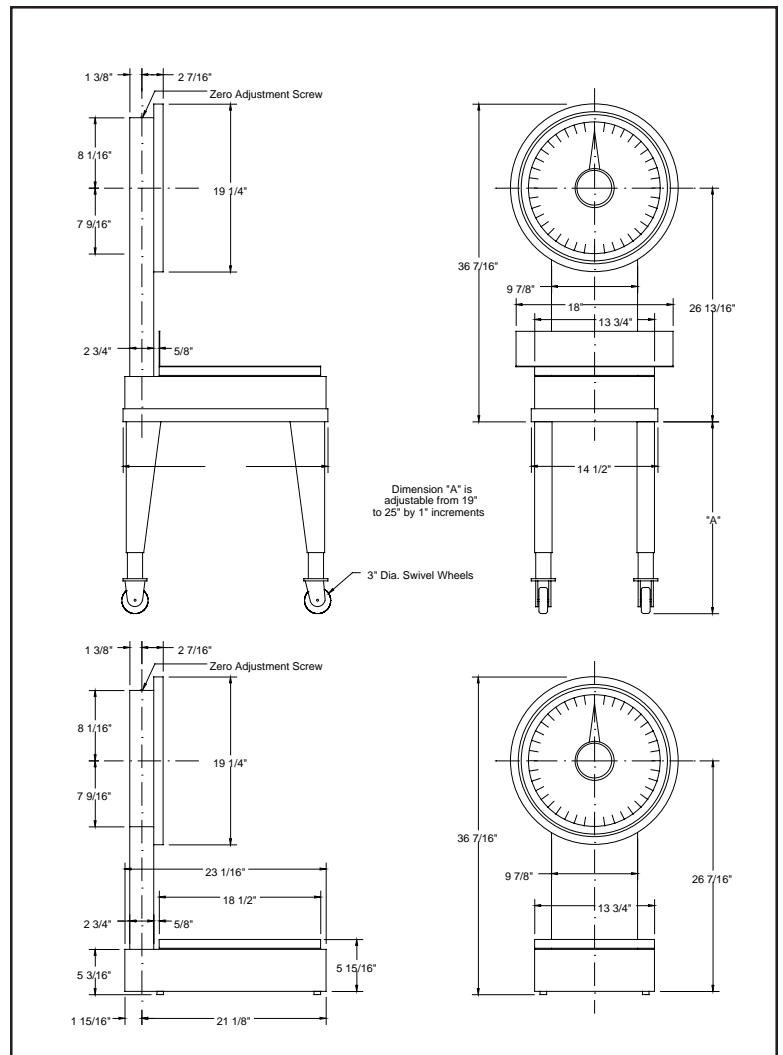

C&M SCALE

Website: www.cmscale.com
 Email: support@cmscale.com

Toll Free: (800) 243-3721
 In Chicago: (708) 771-0195
 Fax: (708) 771-0195